

Progressive Scan Industrial Camera Series Featuring GigE Vision Interface

Near Infrared Camera KP-F145GV

Speed: 1 Gbps
Distance: 100m

GigE Vision Interface Features

GigE™
VISION



Gigabit Ethernet interface

Direct connection is possible to PC by the Gigabit Ethernet cable. This cable is less bulky compared with parallel digital output cabling.

GigE Cable length can be extended to maximum 100m without hub and switcher.

Direct connection to PC and triggered via Ethernet (software trigger)

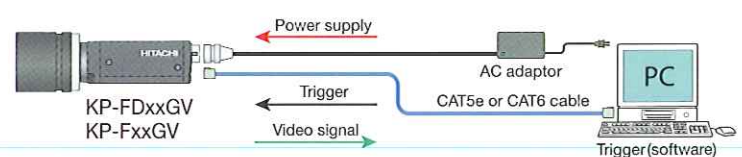

GigE Vision™ (Ver 1.00) compatible

Based on Industrial camera interface standard GigE Vision, a maximum of 1Gbps high speed data transmission is available and suitable for image processing.

Direct connection to PC and triggered via multi-connector (Hardware trigger)

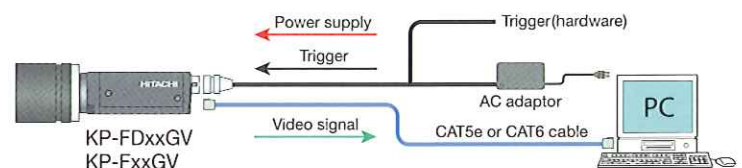

GENiCAM™ (Ver 1.00) compatible

Development of camera control system is easy because industrial camera control API "GENiCAM" lead EMVA (European Machine Vision Association).

Connection via HUB/switcher to PC and power supply via the Ethernet (PoE)

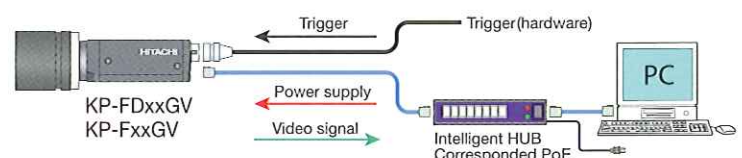

PoE correspondence

Power supply can be input via Ethernet cable (Power over Ethernet).

Main Features

1. Versatile CCD drive functions

- Auto electronic Shutter mode (AES)
Adjusted automatically from 10 second to approx. 1/100,000 second.
- Preset electronic shutter mode Multi-step up to 1/50000 second in 8 steps.
- Variable electronic shutter mode Variable at 1H steps from 10 second to approx. 1/100,000 second.

2. External trigger

An external trigger signal input can be used to capture an image at desired timing for instant view or processing. The software trigger via a Gigabit Ethernet cable and the hardware trigger can deal with all trigger signals.

Spectrum sensitivity characteristic
(Example of representative characteristic)

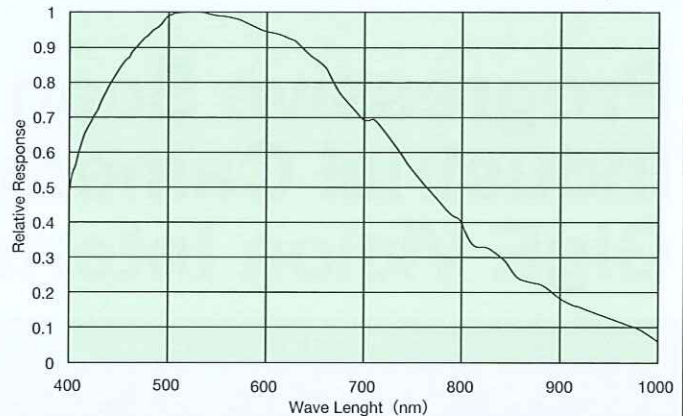

Main specifications

Model	KP-F145GV
Imaging device	2/3-inch interline CCD
Effective pixels	1392(H) × 1040(V)
Unit cell size	6.45μm(H) × 6.45(V) (square lattice)
Scanning system	Progressive
Sync system	Internal / External
Video system	GigE Vision
Frame rate	30 frames per second (full pixel readout)
Data format	Mono 8/10/12bit
Power supply voltage	DC+12 V plus minus 1V (input from 12-pin connector), 48 V (PoE)
External dimensions	44(W) × 29(H) × 72(D)mm
Mass	Approx.140g

Dimensions

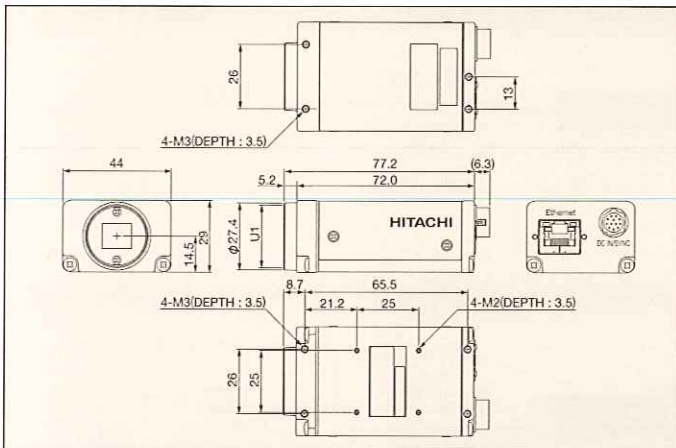

Rear View

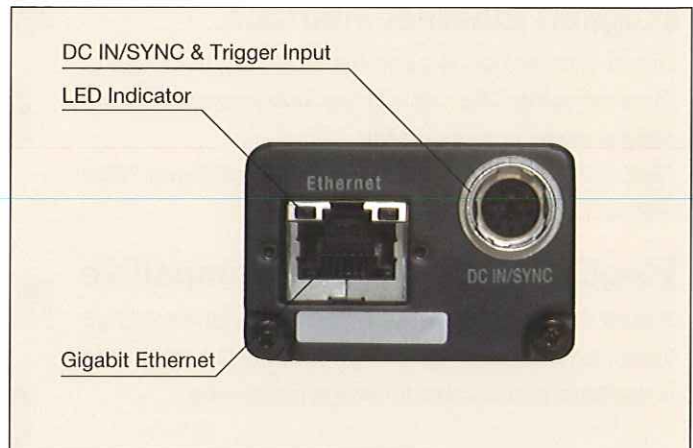

CAUTION : To ensure safe operation, please read the instruction manual before using this product.

These Specifications are subject to change without notice.

Hitachi Kokusai Electric Inc. URL: <http://www.hitachi-kokusai.co.jp>

Head Office: AKIHABARA UDX Bldg. 11F, 4-14-1 Sotokanda 4-choume, Chiyoda-ku, Tokyo 101-8980, Japan
Phone : +81 (0) 3-6734-9432 Fax : +81 (0) 3-5209-5942

Hitachi Kokusai Electric America, Ltd. URL: <http://www.hitachikokusai.us>
Head Quarters and: 150 Crossways Park Drive, Woodbury, New York 11797, U.S.A.

Northeast Office: Phone : +1 516-921-720 Fax : +1 516-496-3718
West Office: 371 Van Ness Way, Suite 120 Torrance, CA. 90501
Phone : +1 310-328-6116 Fax : +1 310-328-6252

Midwest Sales: Phone : +1 330-334-4115 Fax : +1 516-496-3718 Service : +1 989-345-5379
South Sales: Phone : +1 850-934-1234 Fax : +1 516-496-3718 Service : +1 256-774-3777
Latin Sales: Phone : +1 516-682-4408 Fax : +1 516-496-3718

Parts Center: Phone : +1 516-682-4435 Fax : +1 516-921-0993

Hitachi Kokusai Electric Canada, Ltd. URL: <http://www.hitachikokusai.ca>
Head Office: 1 Select Avenue, Unit #12, Scarborough, Ontario M1W, 5J3, Canada
Phone : +1 416-299-590 Fax : +1 416-299-0450

Eastern Office: 5795 Chemin St. Francois St. Laurent, Quebec H4S, 1B6, Canada
Phone : +1 514-332-6687 Fax : +1 514-335-1664

Hitachi Kokusai Electric Europe GmbH URL: <http://www.hitachi-keu.com>
Head Office: Gruetener Str.3, D-40699 Erkrath, Germany
Phone : +49(0) 2104-96550 Fax : +49(0) 2104-40039

Frankfurt Office: Siemensstr.9, D-63263 Neu-Isenburg, Germany
(Central office) Phone : +49(0) 6102-83320 Fax : +49(0) 6102-202616
Europe) General email address: info@hitachi-keu.com

Hitachi Kokusai Electric U.K. Ltd.

Head Office: Windsor House, Queensgate, Waltham Cross, Herts. EN8 7NX, United Kingdom
Phone : +44(0) 845-121-2177 Fax : +44(0) 845-121-2180
General email address: info@hitachi-keu.com

Hitachi Kokusai Electric (Shanghai) Co., Ltd.

Beijing Branch: Room 1415, Beijing Fortune Building, 5 Dong San Huan Bei-Lu, Chao Yang District, Beijing 100004
Phone : +86(0) 10-6590-8755/8756 Fax : +86(0) 10-6590-8757
A25, Bei San Huan Zhong Road Chao Yang District, Beijing 100029

Beijing Service Center: Phone : +86(0) 10-6204-3901/3903 Fax : +86(0) 10-6204-3902



CERTIFICATE No.
JMI-0062
ISO 9001/BS 5750Pt1
EN 29001/JIS Z9901